



Инструкция по установке



# Toyota Land Cruiser Prado 150

(2003-2009 / 2009-)

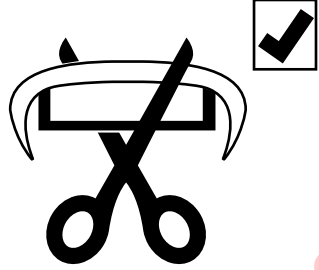

Арт.: F.5714.003

 <b>2200 kg</b>	 <b>120 kg</b>	<b>D = 12,27 kN</b>	
---	--	---------------------	---

<b>D (kN) =</b>	 MAX kg    X    MAX kg	<b>x 0,00981</b>
	 MAX kg    +    MAX kg	

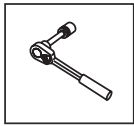

Вкрутить/выкрутить используя инструмент

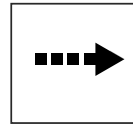

Движение

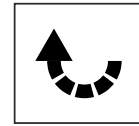

Поворот



Вкрутить/выкрутить не затягивая

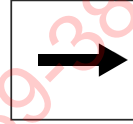





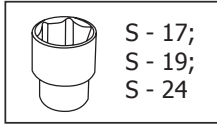
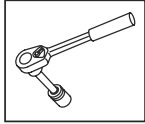



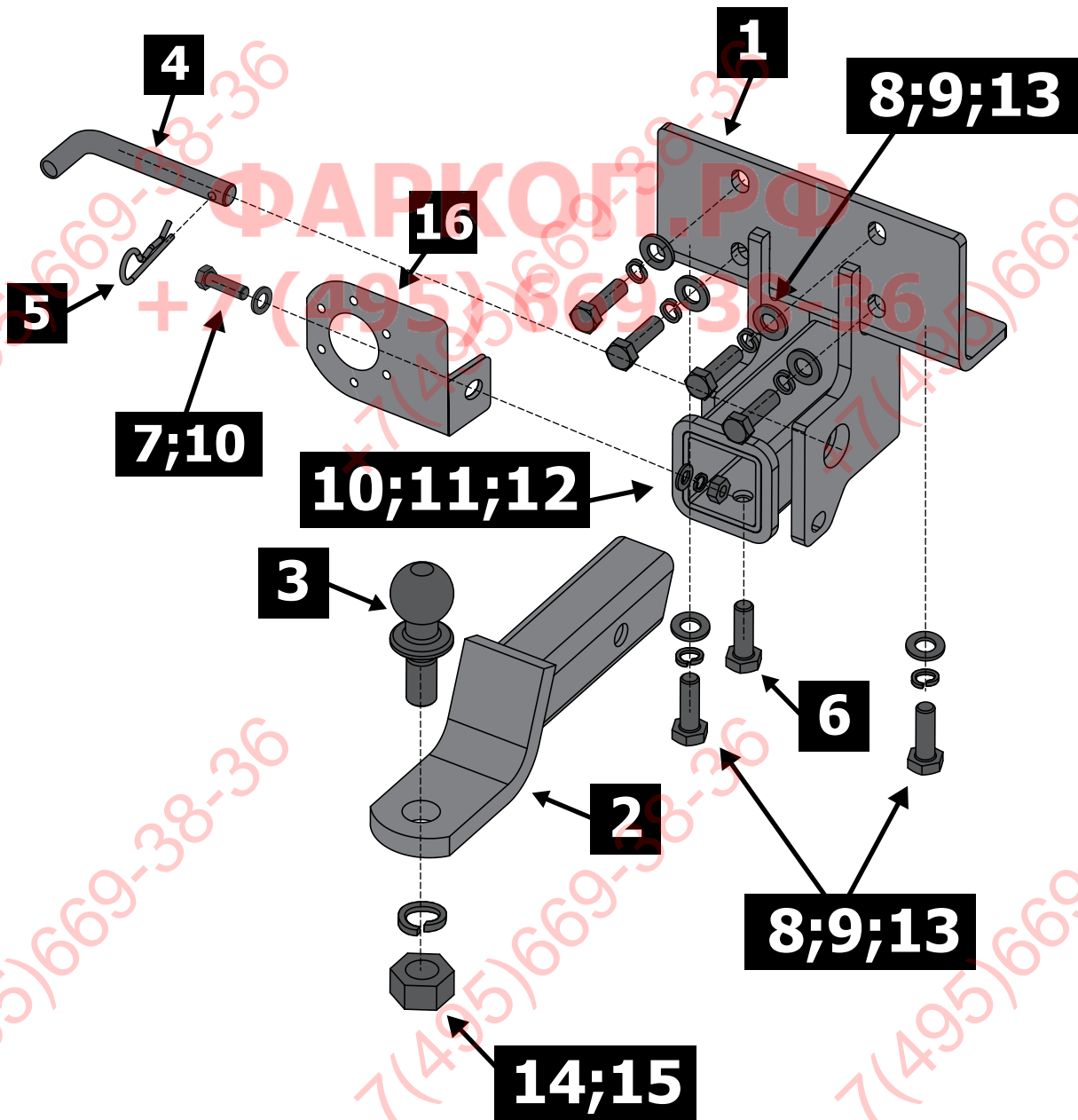

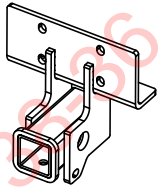
Расположение

### Используемый инструмент:

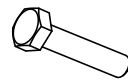

S - 17;  
S - 19;  
S - 24



<b>1</b>	x1	 Кронштейн	<b>2</b>	x1	 Адаптер
<b>3</b>	x1	Шар			
<b>4</b>	x1	Штифт			
<b>5</b>	x1	Шплинт пружинный			
<b>6</b>	x1	M10x20			
<b>7</b>	x1	M10x30			
<b>8</b>	x6	M12x40			
<b>9</b>	x6	∅ 12			
<b>10</b>	x2	∅ 10			
<b>11</b>	x1	∅ 10			
<b>12</b>	x1	M10			
<b>13</b>	x6	∅ 12			
<b>14</b>	x1	M24			
<b>15</b>	x1	∅ 24			
<b>16</b>	x1	Подрозетник			

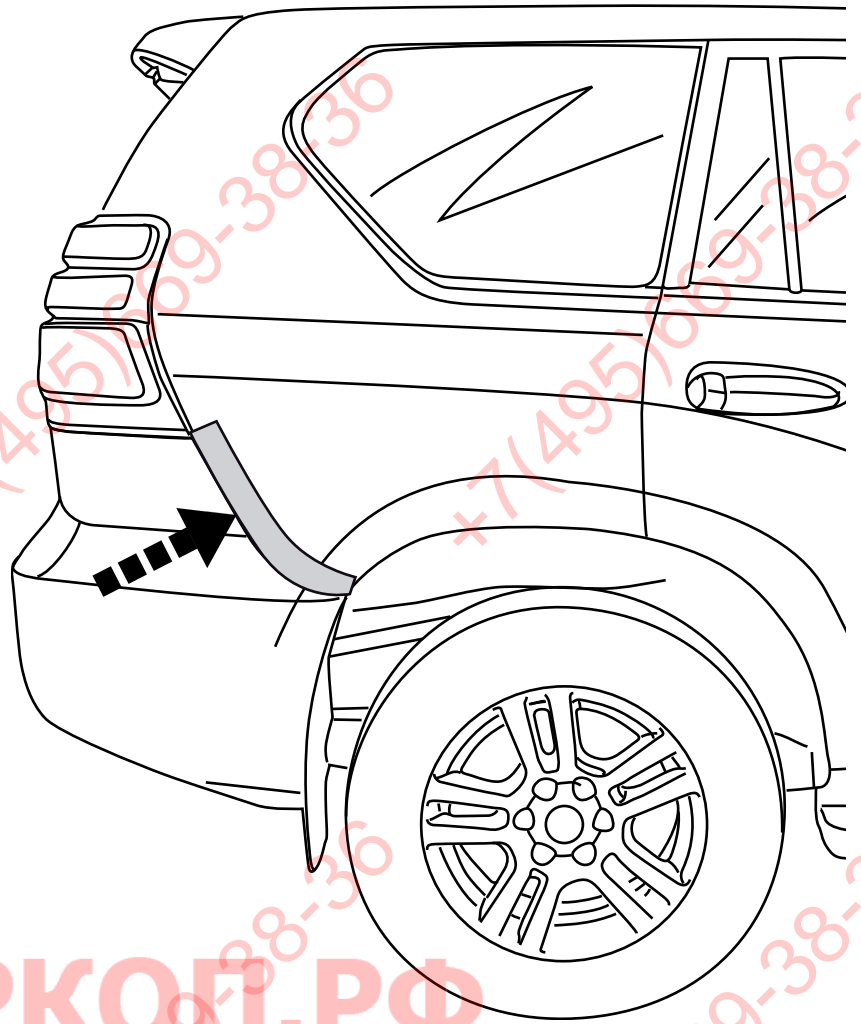
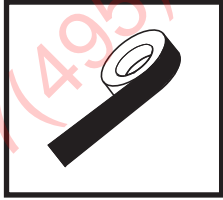
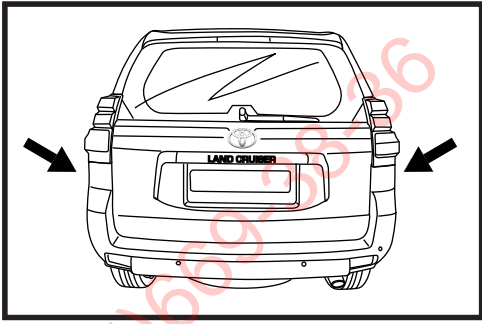

**1**

ФАРКОГ.РФ

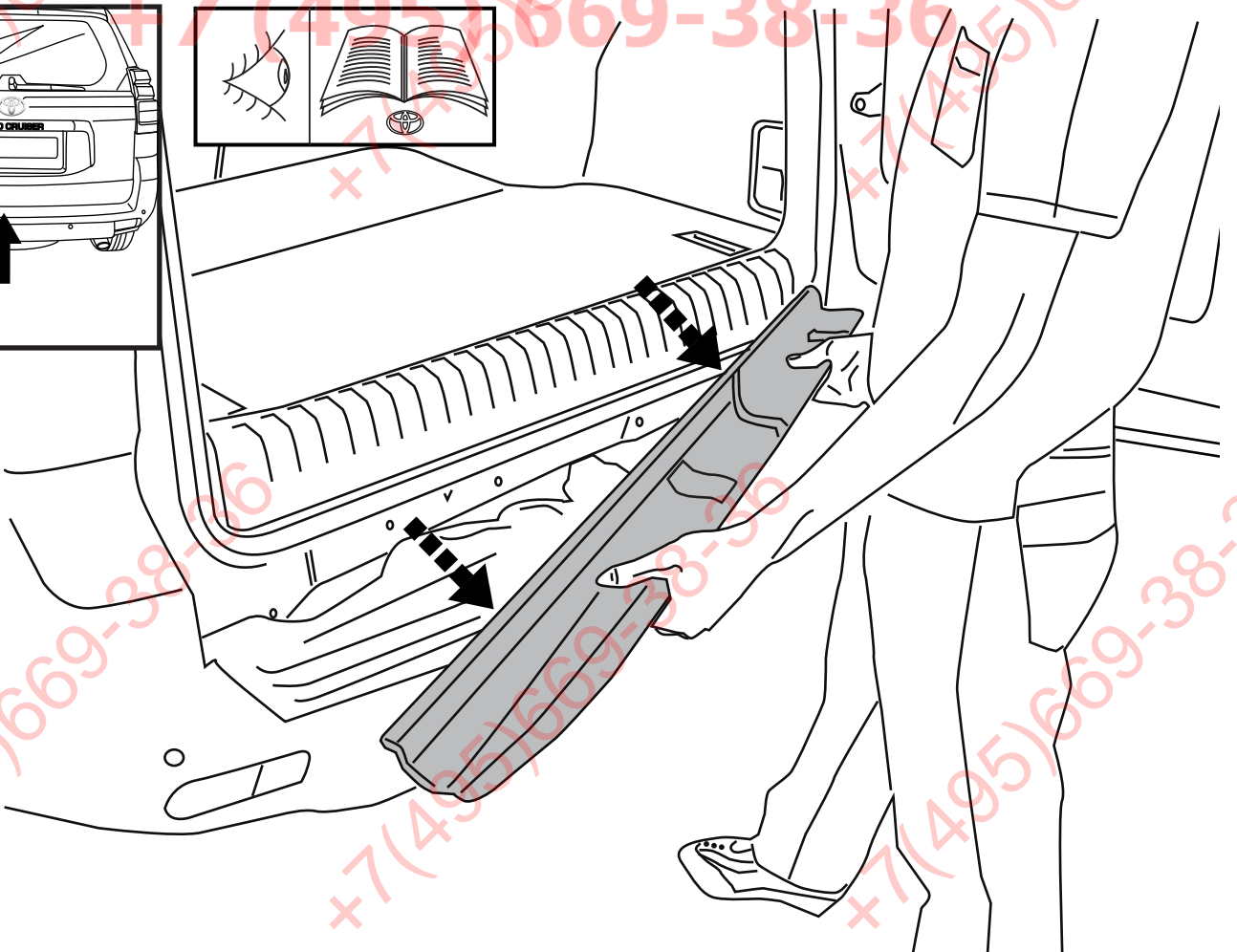
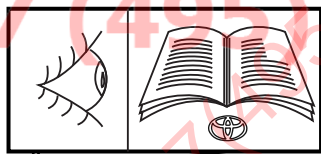
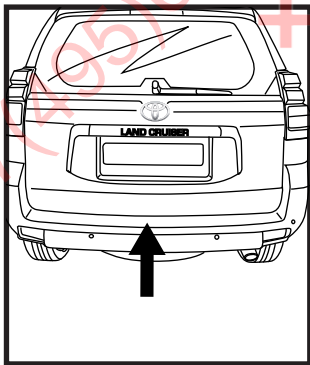

**2**

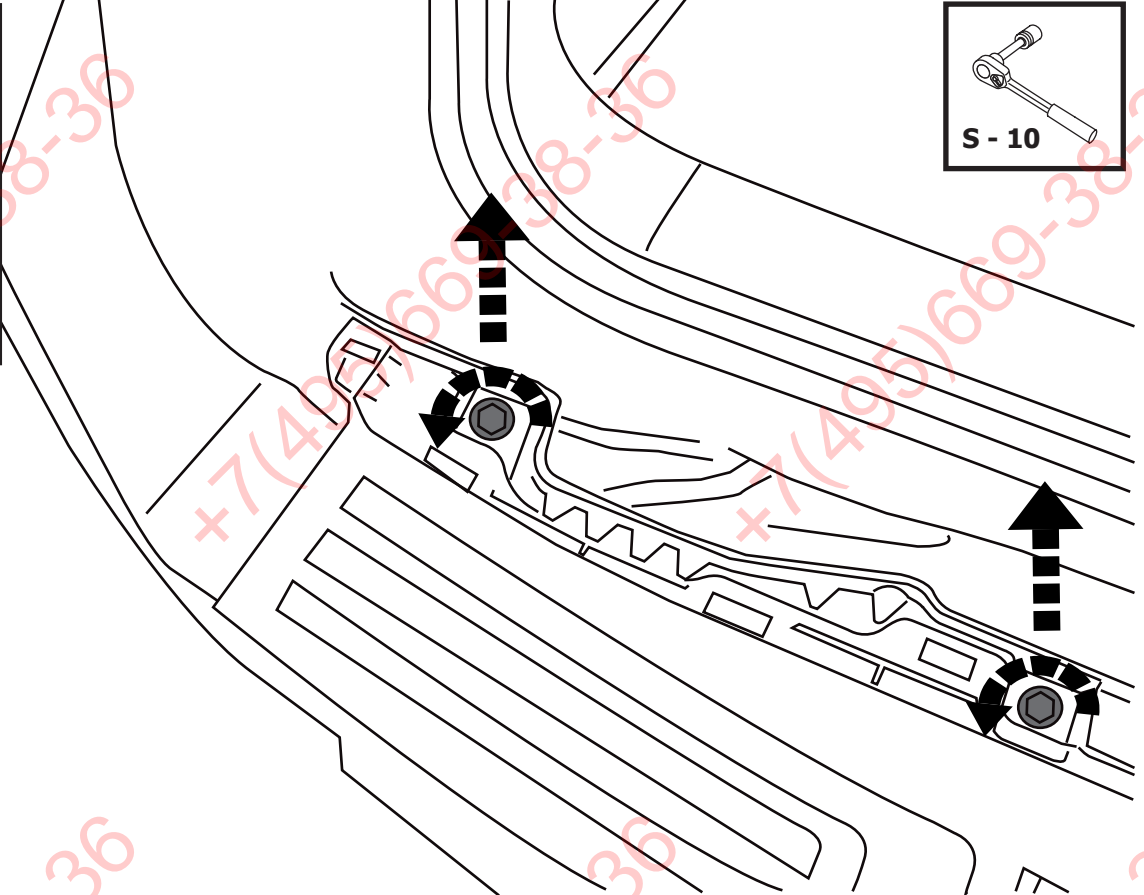
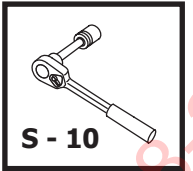
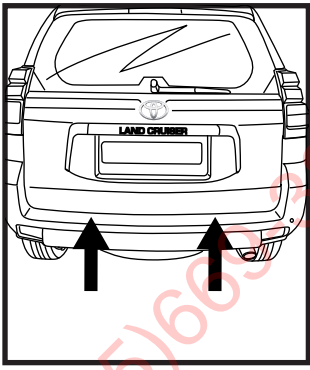

**3**

**ФАРКОГ.РФ**

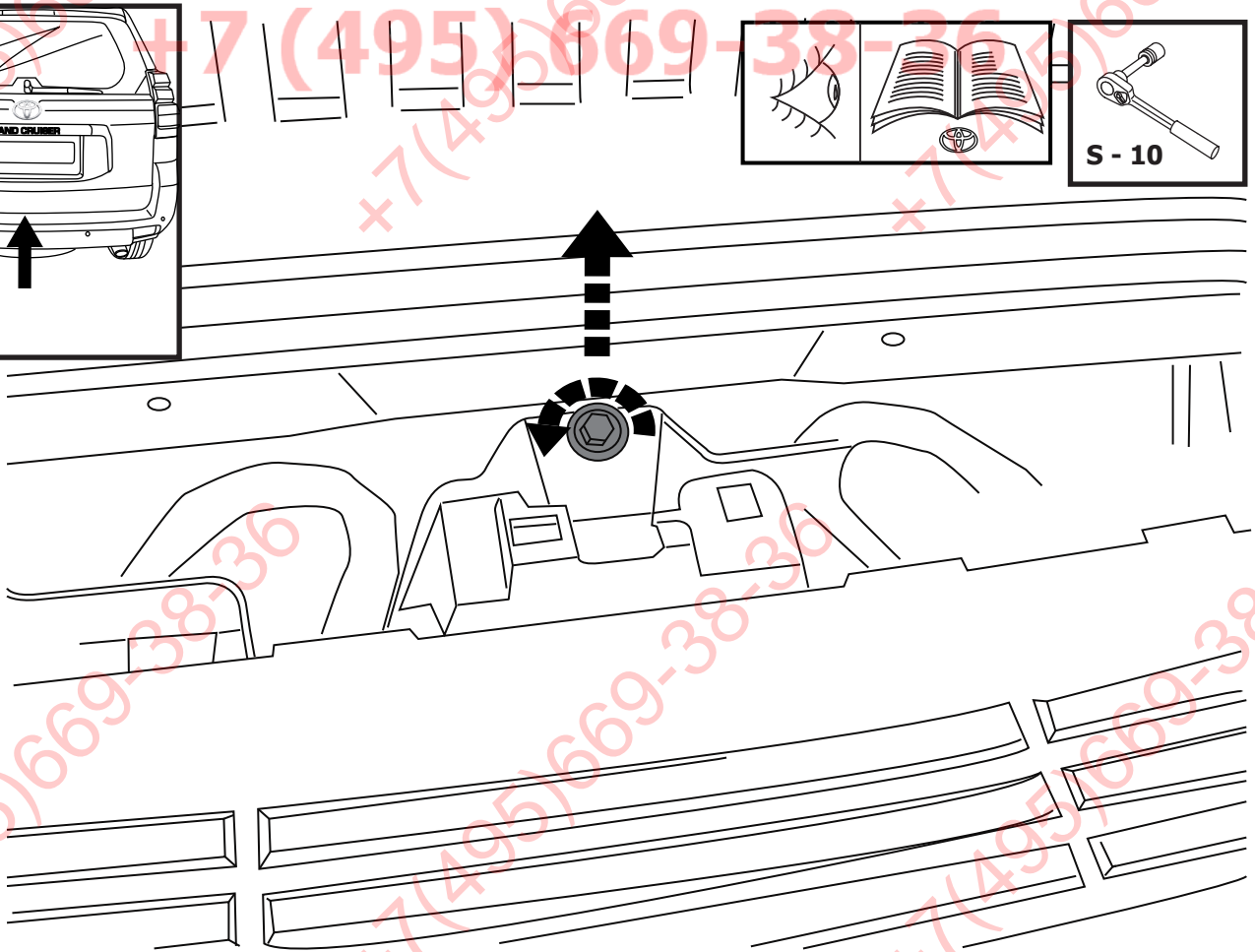
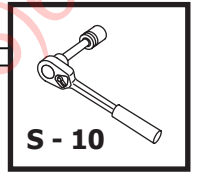
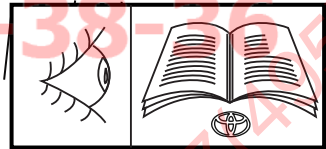
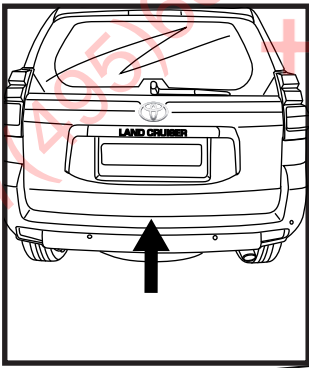

**4**

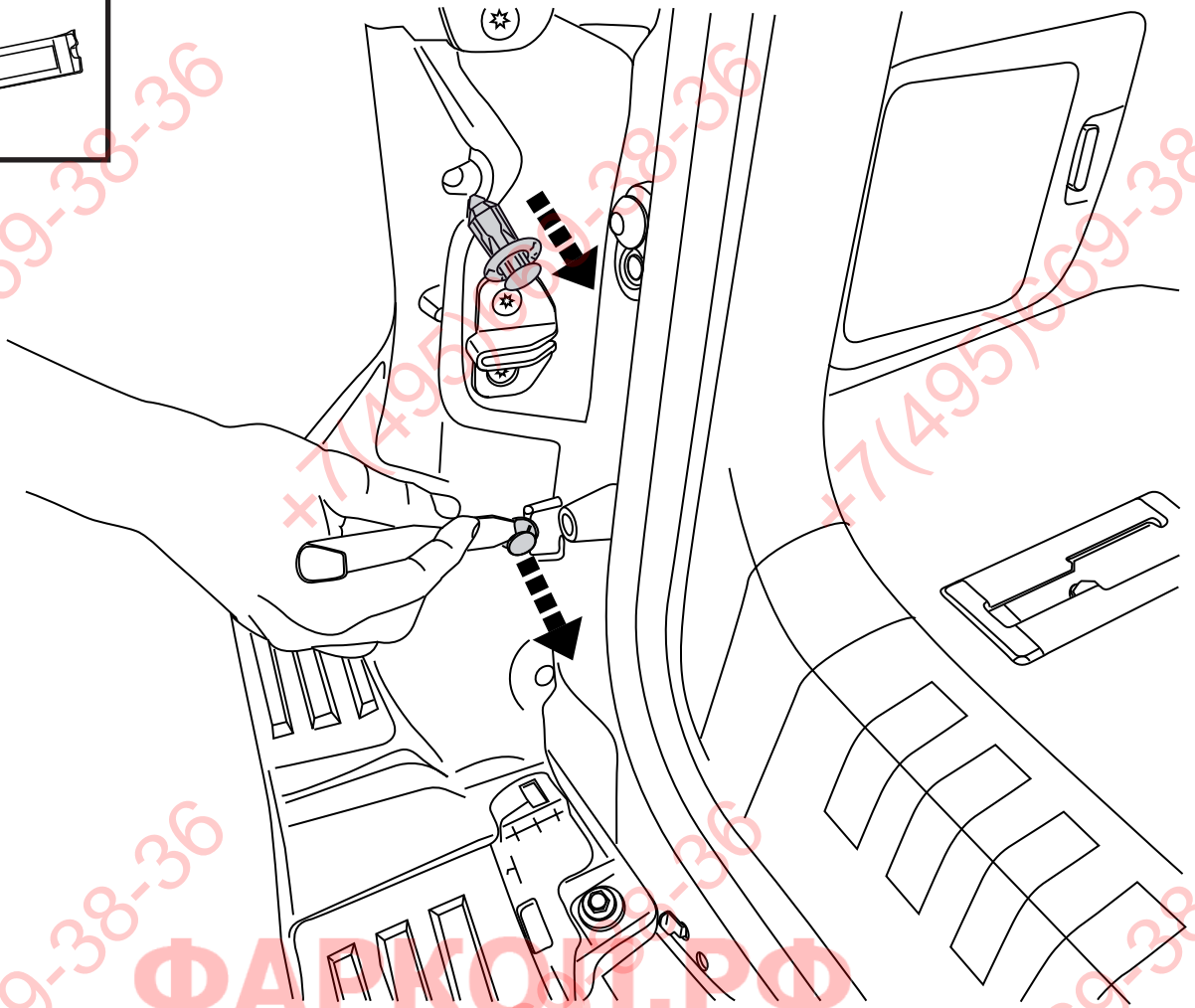
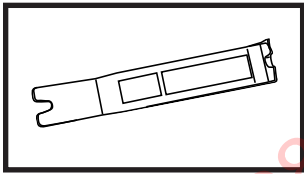

**5**

ФАРКОУТ.РФ

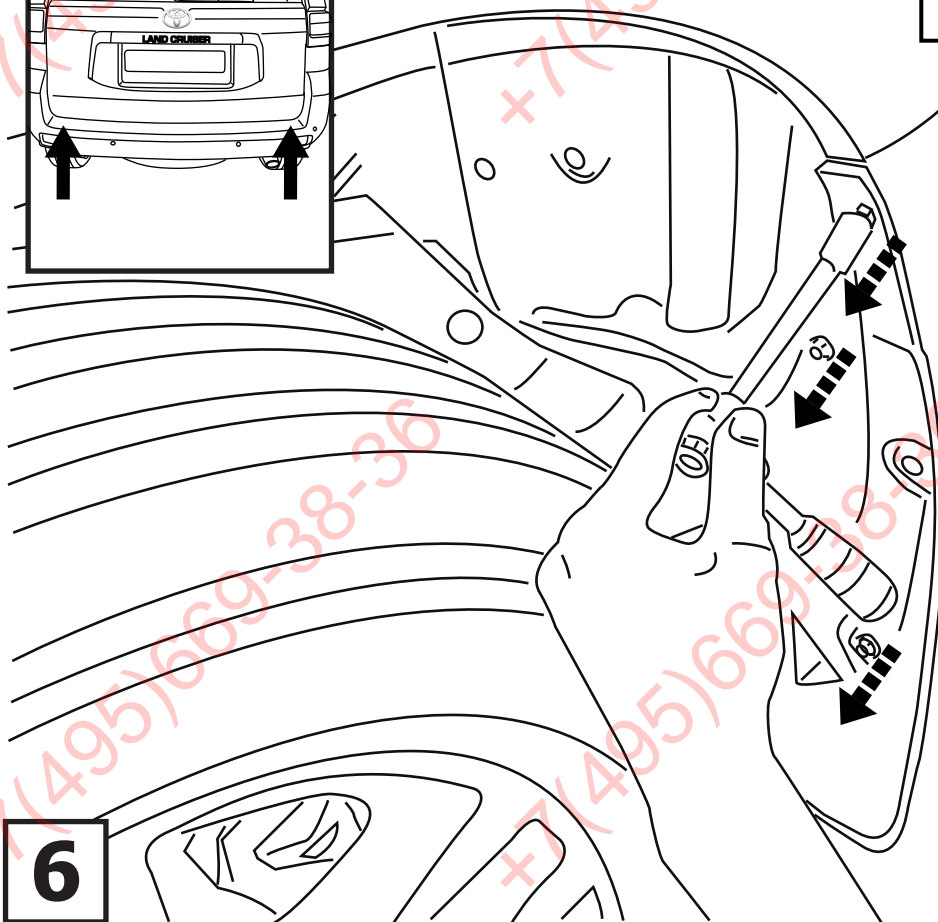
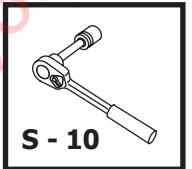
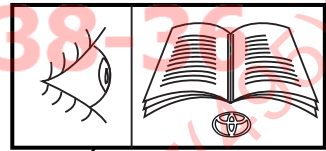
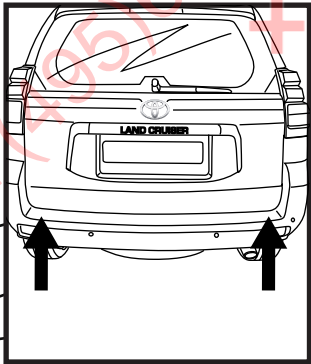

**6**

+7(495)669-38-36

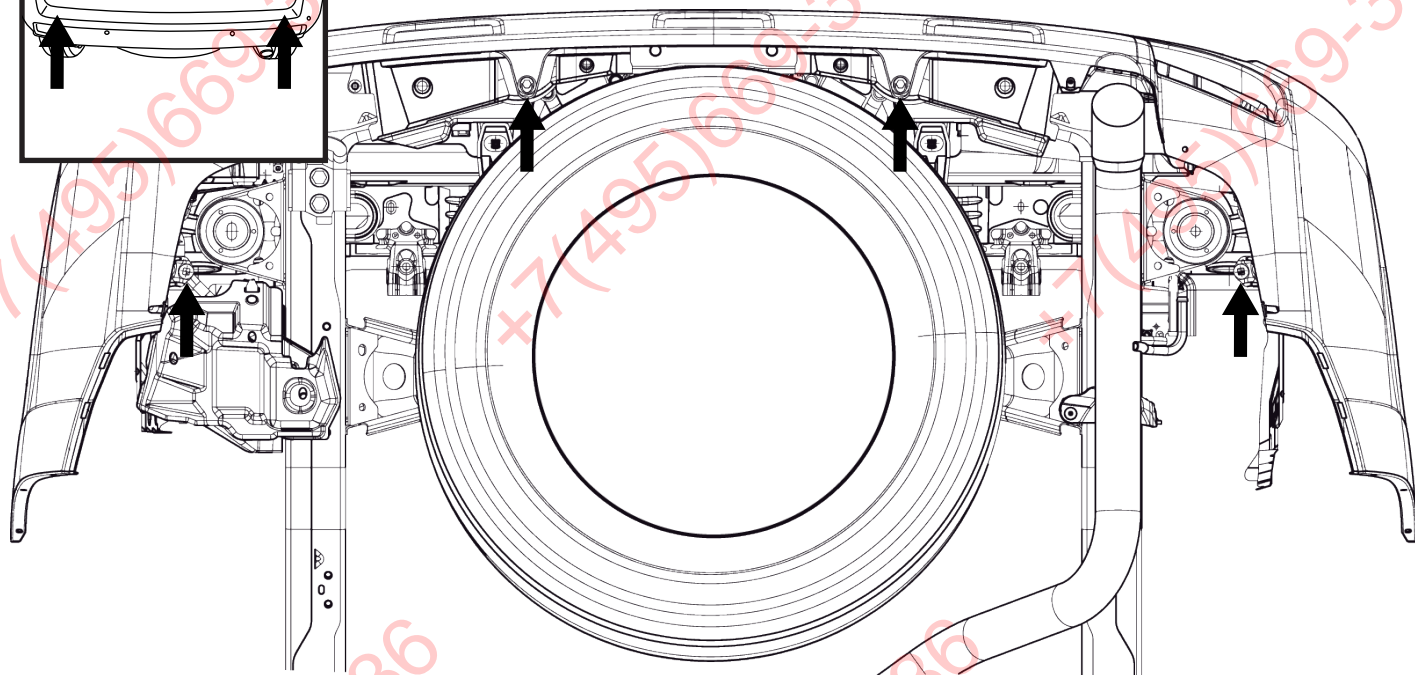
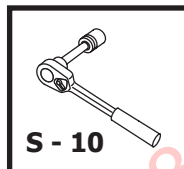
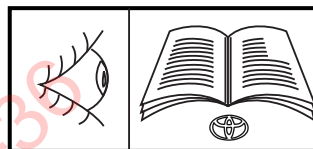
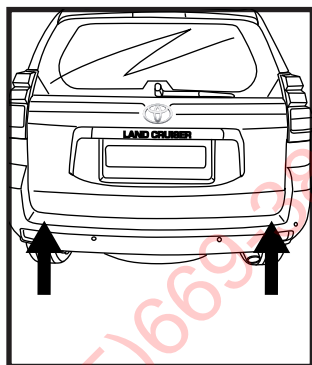

**7**

**ФАРКОГ.РФ**

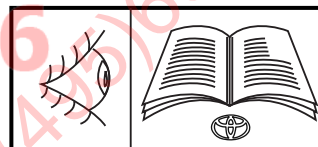
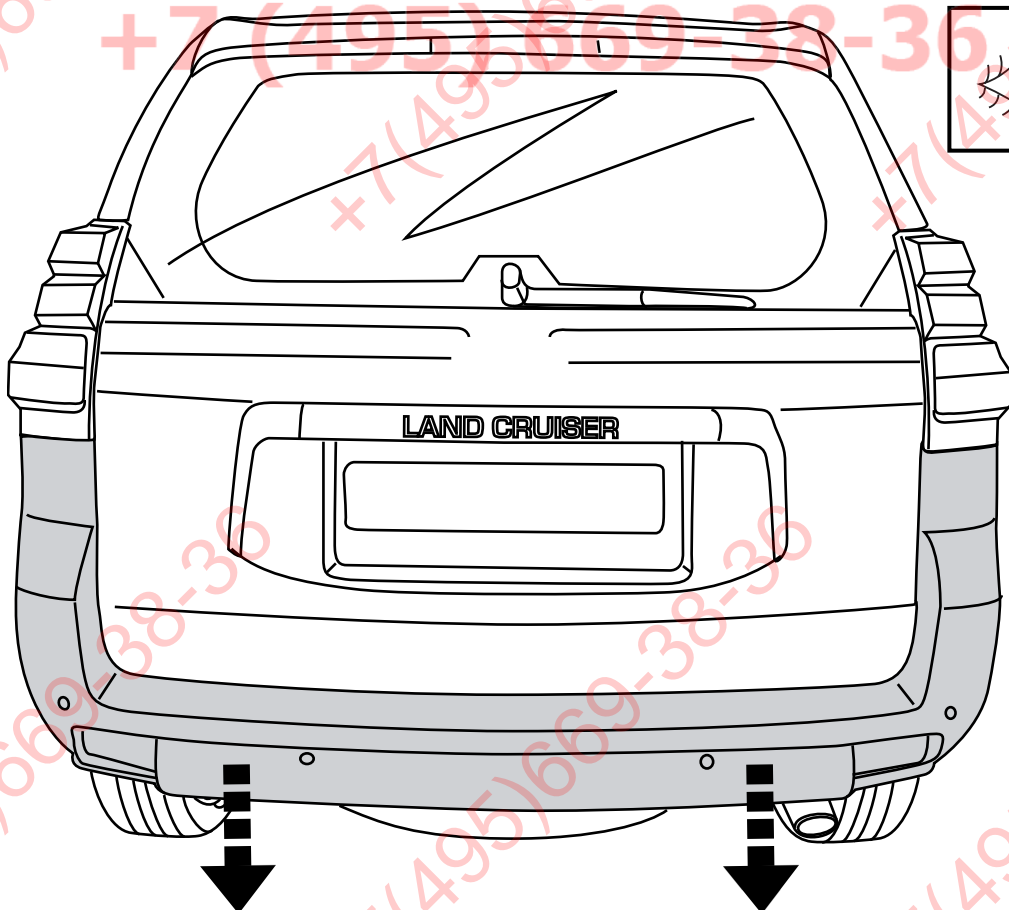

**8**

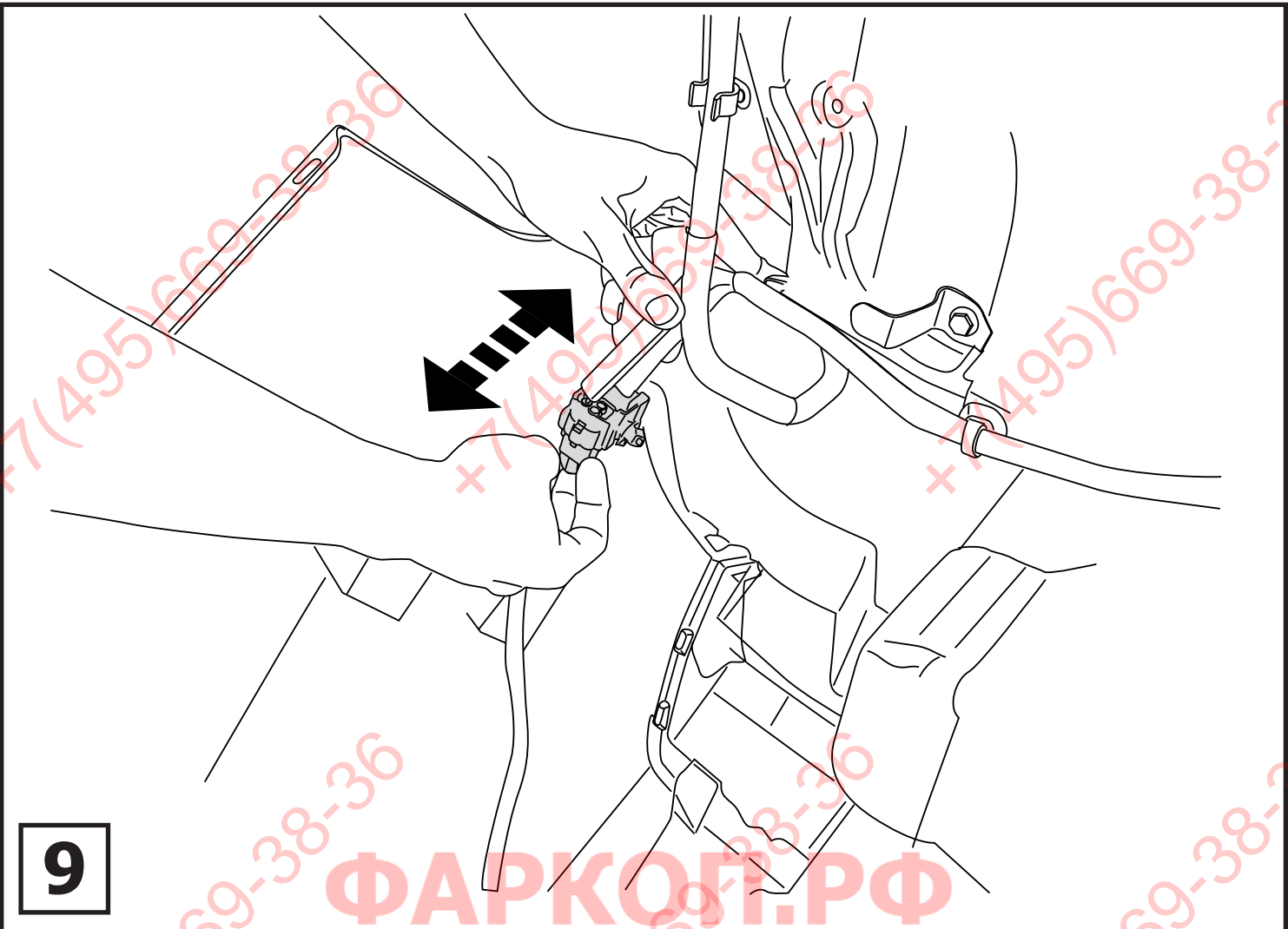



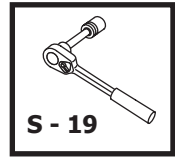
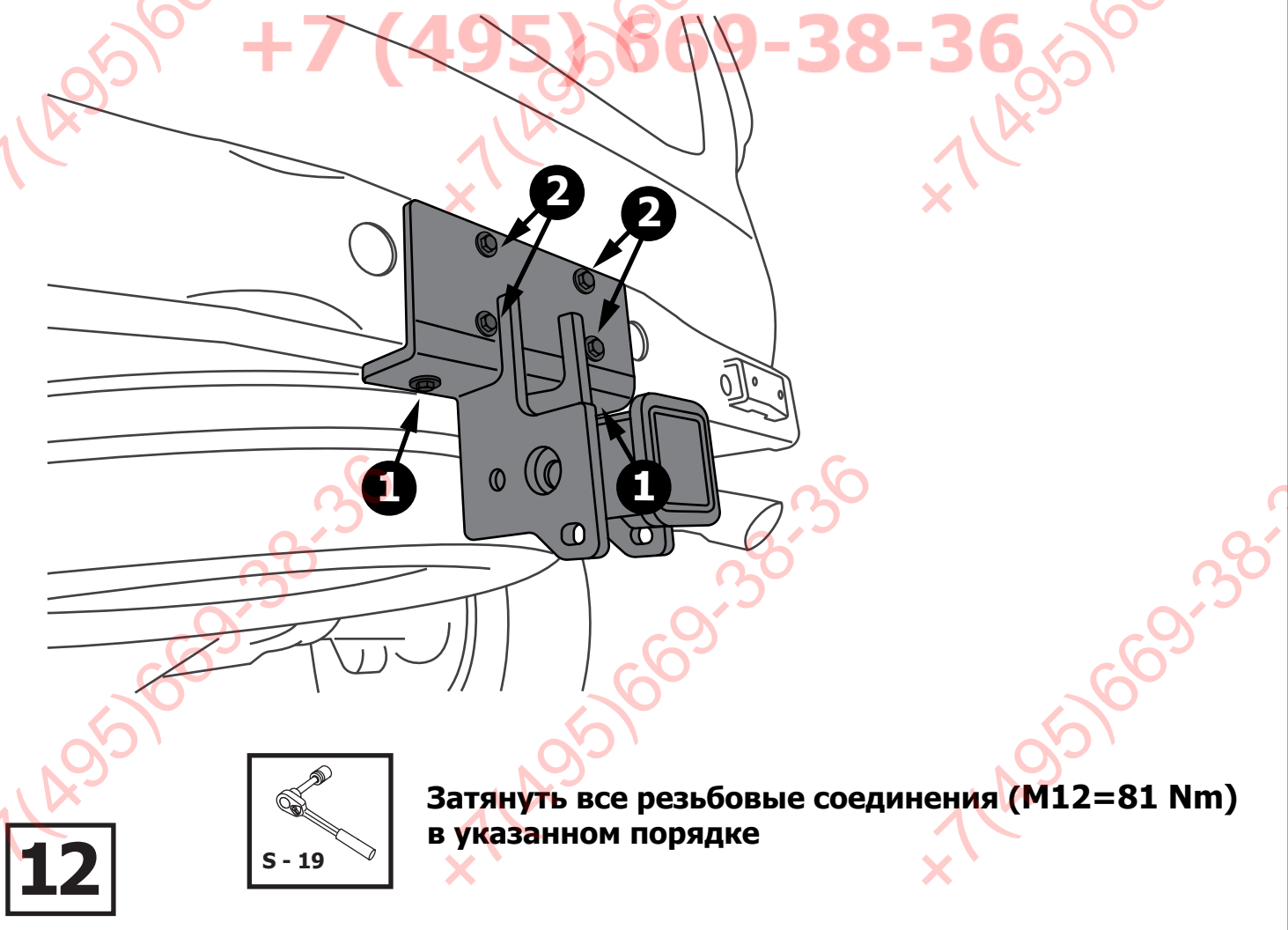
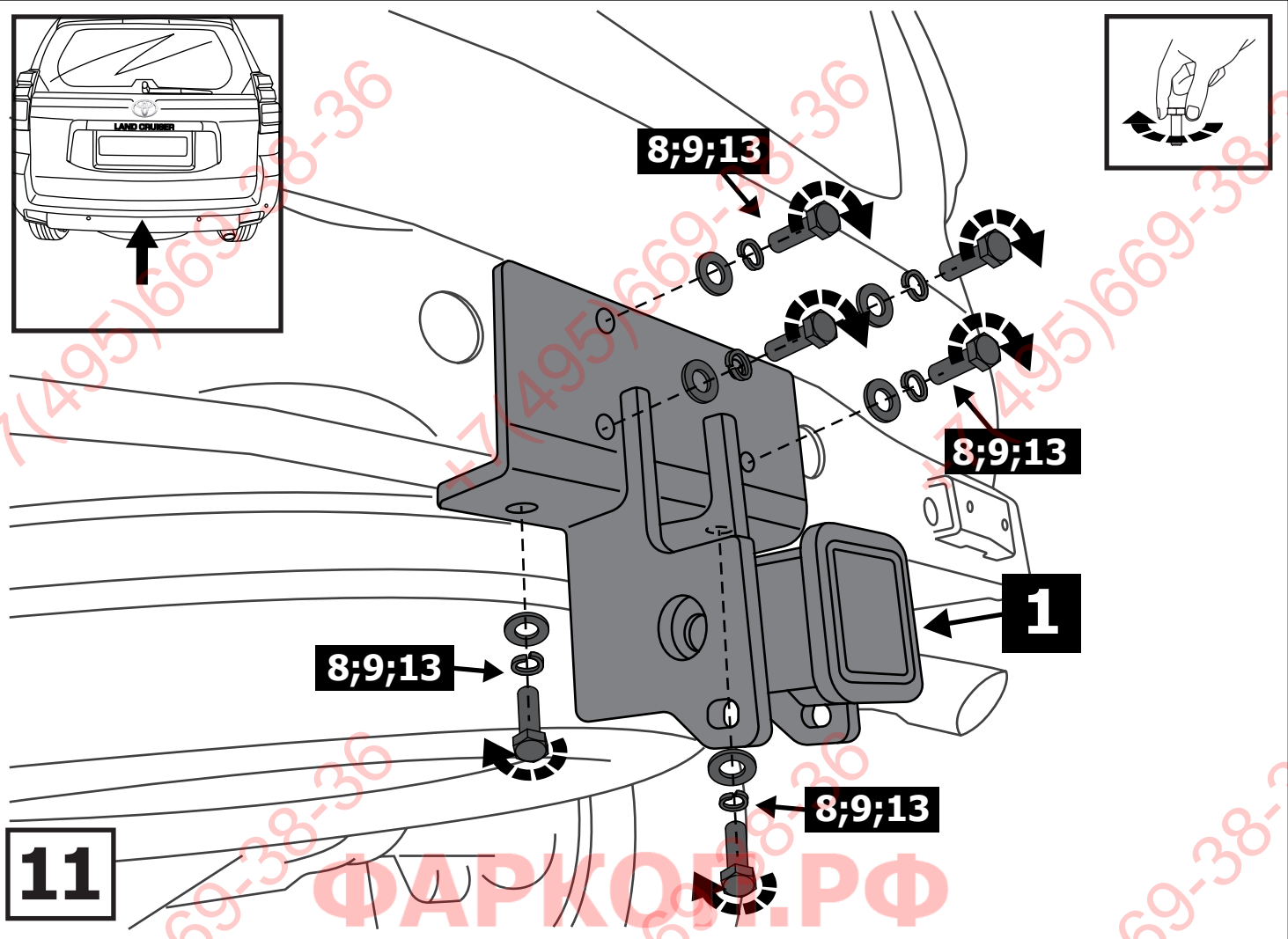
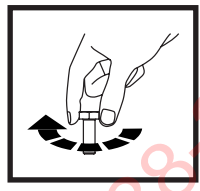
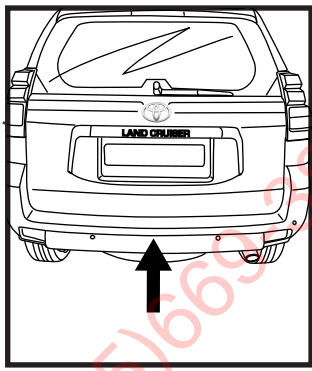

**Затянуть все резьбовые соединения (M12=81 Nm) в указанном порядке**

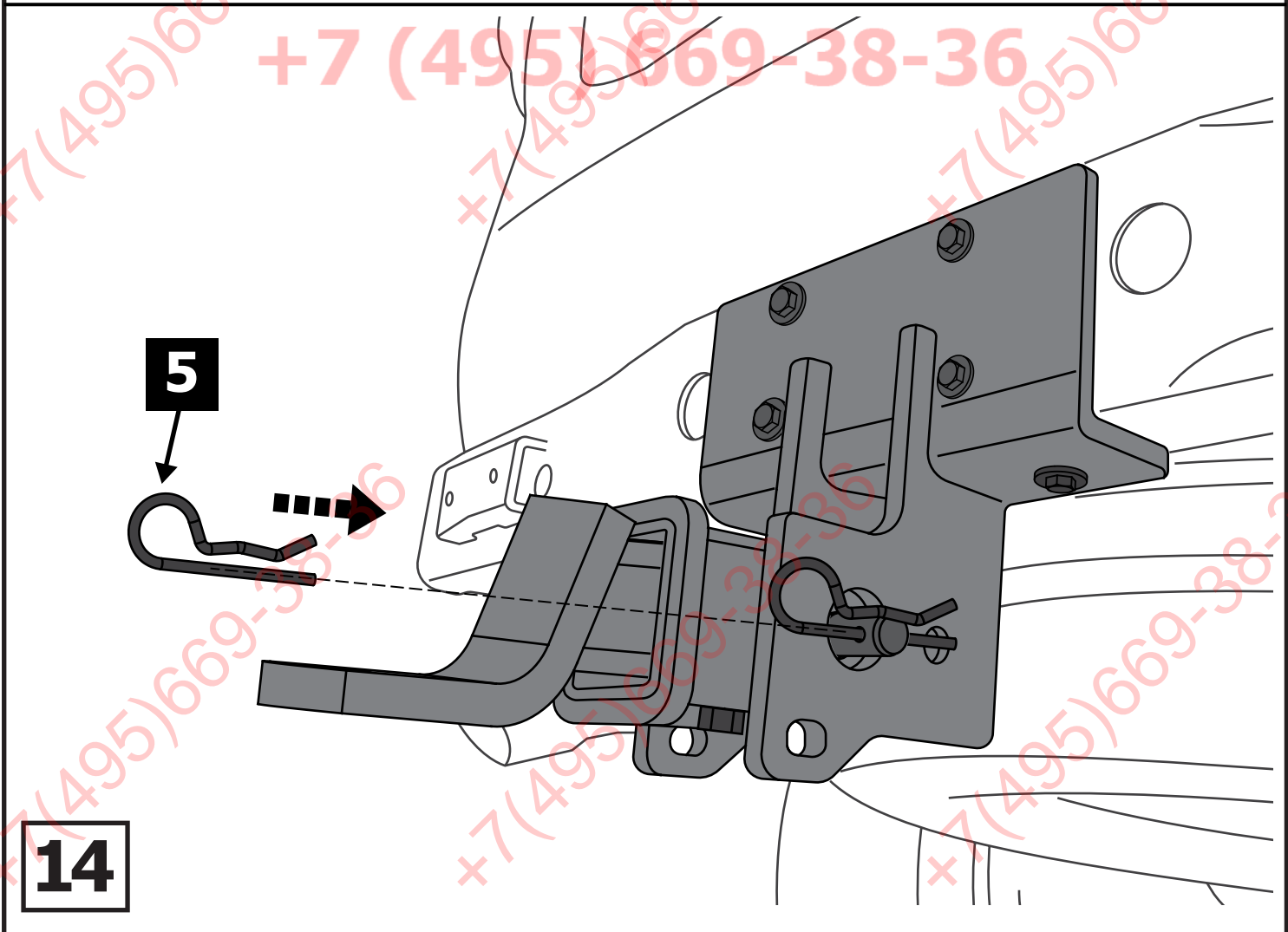
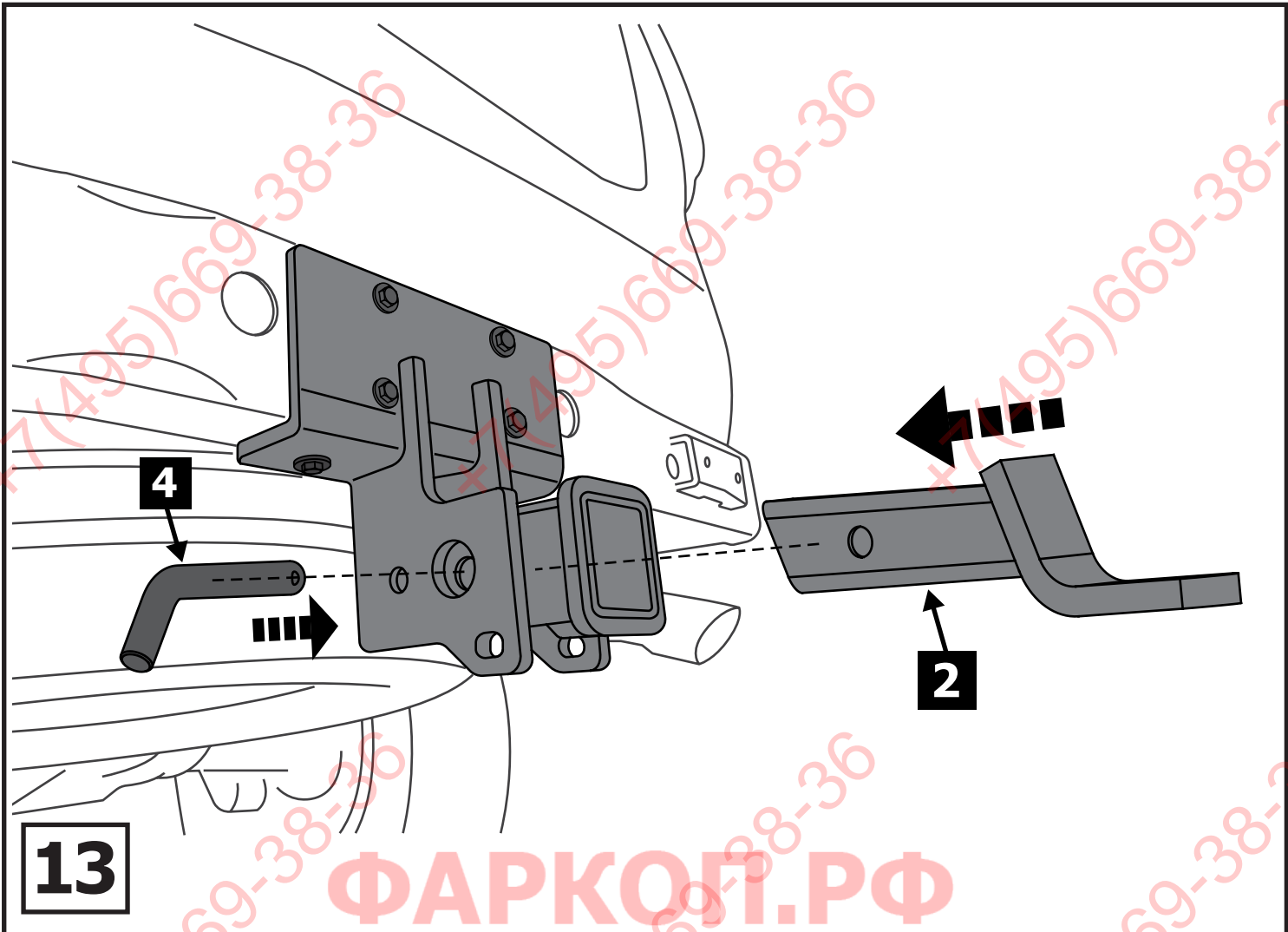

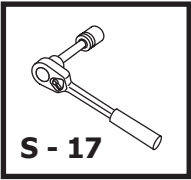

S - 17

M10 = 50 Nm

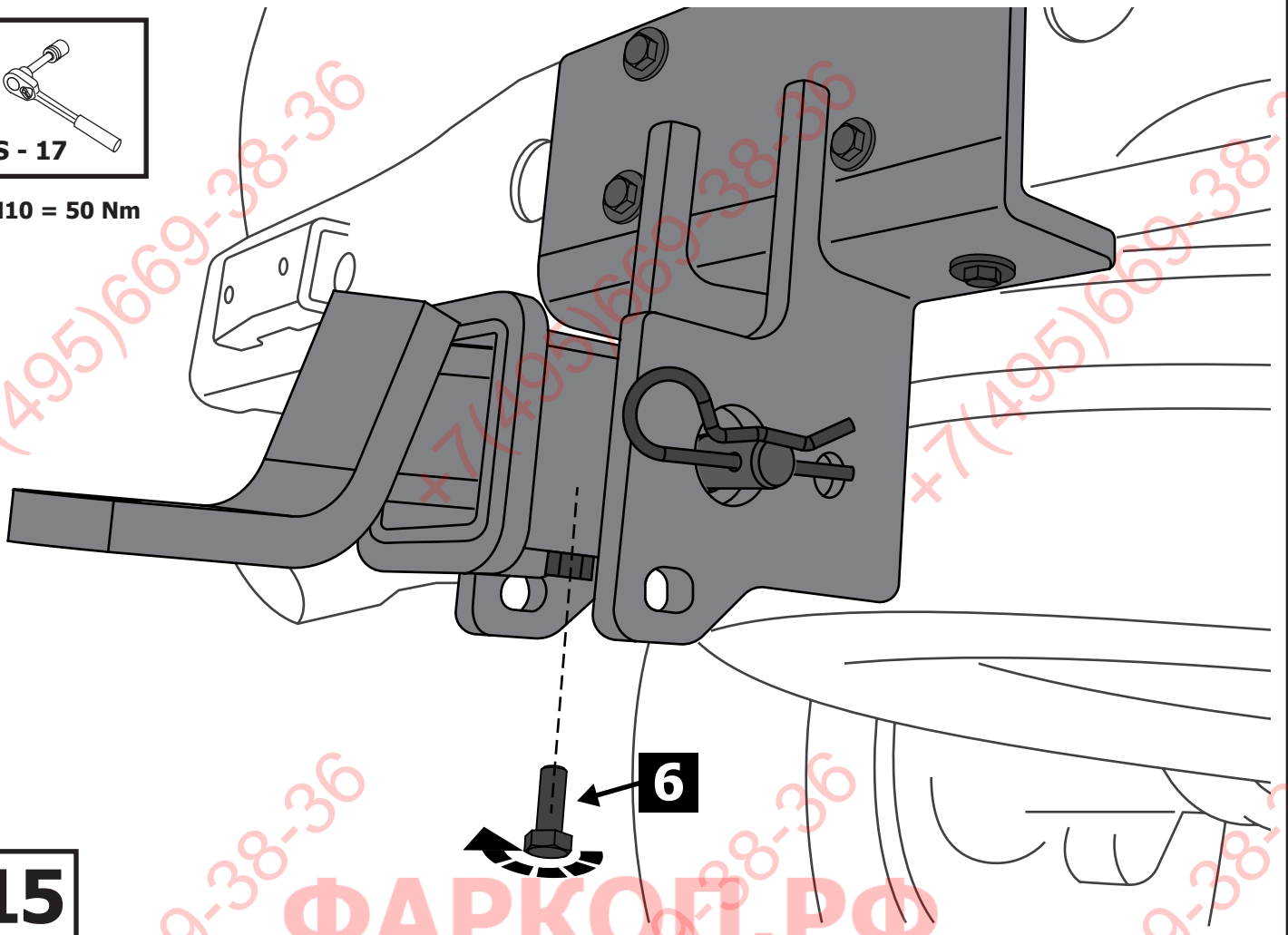

15

ФАРКОГ.РФ

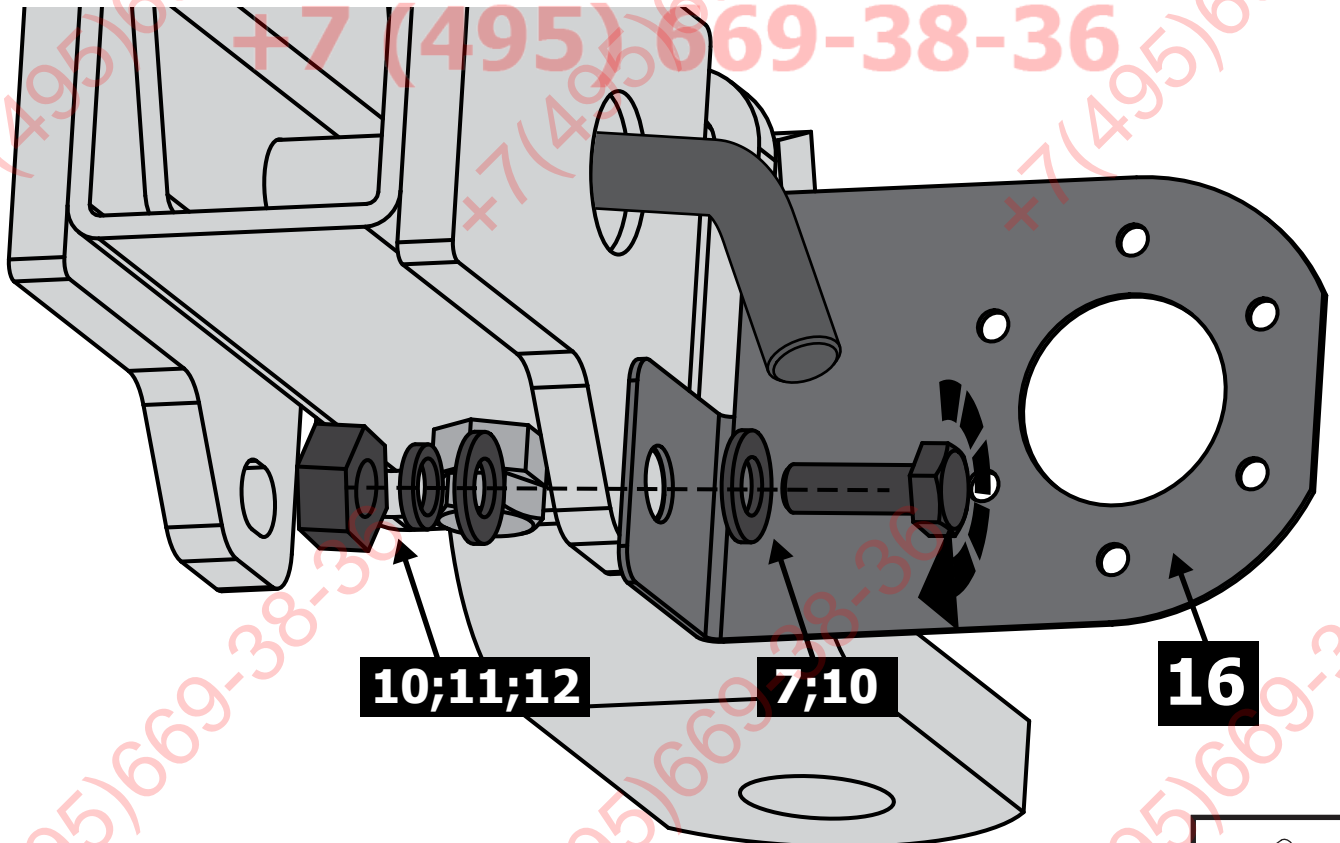

16

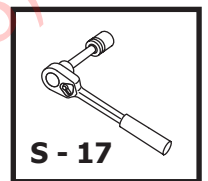

S - 17

M10 = 50 Nm

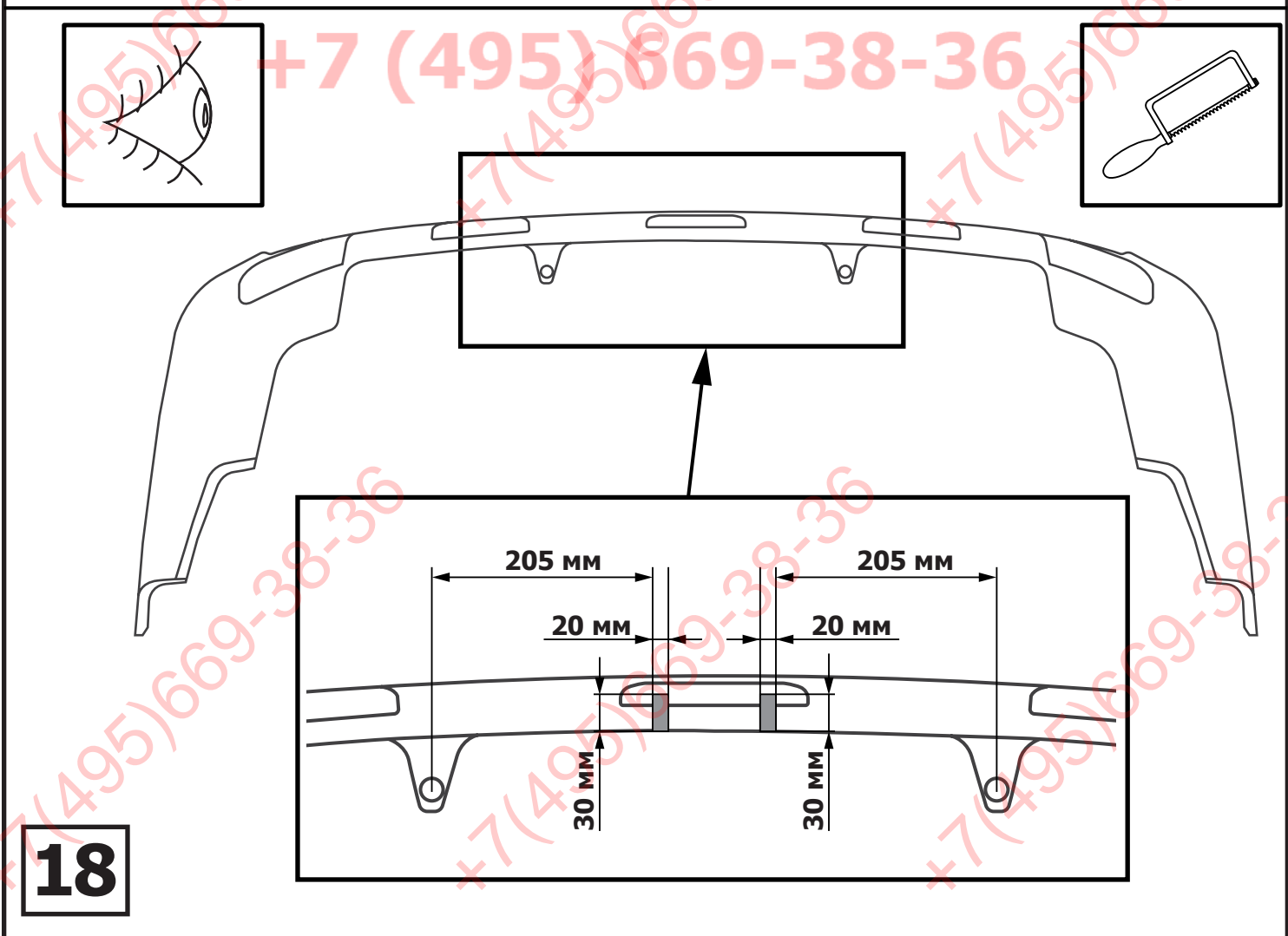
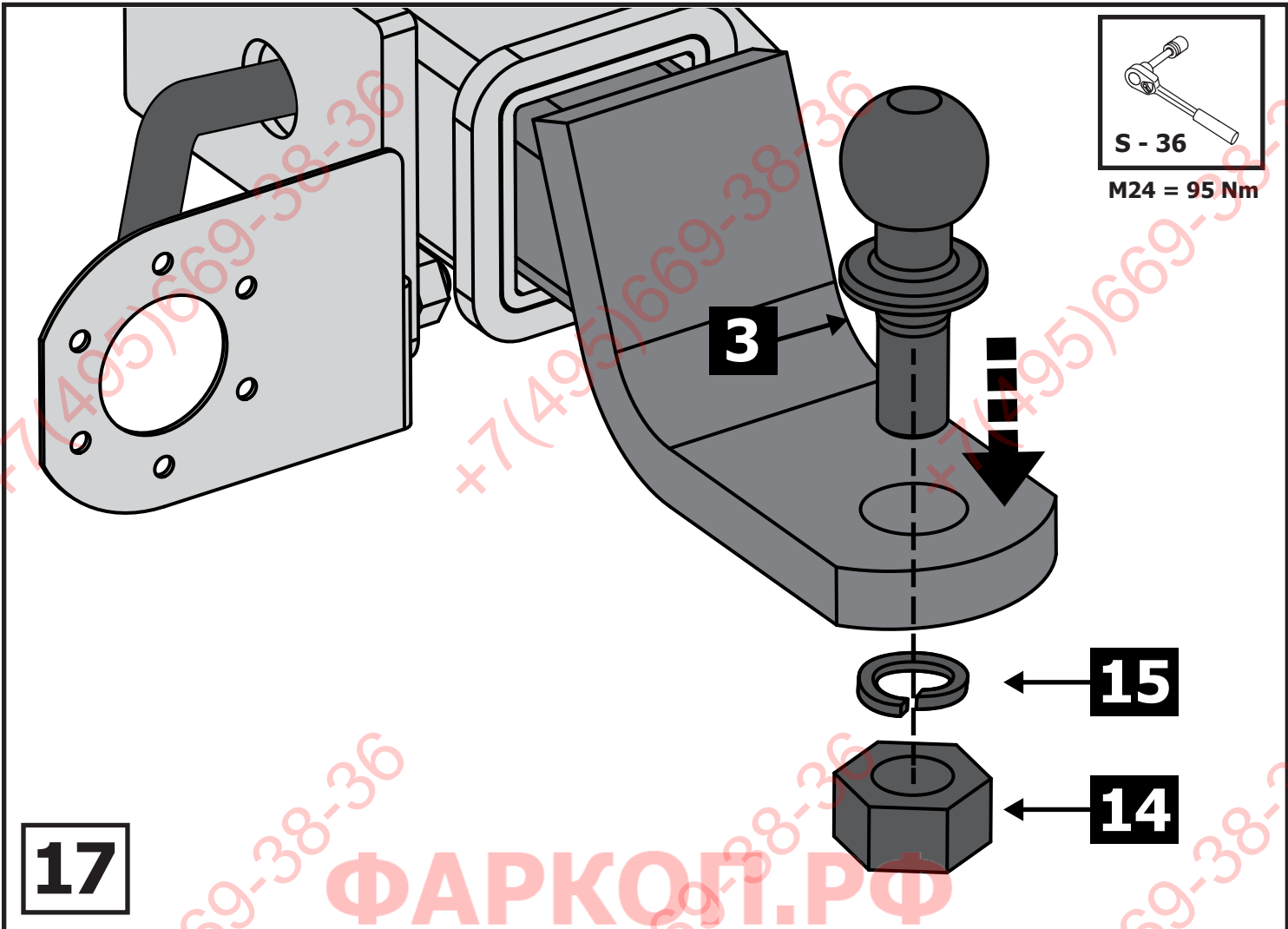

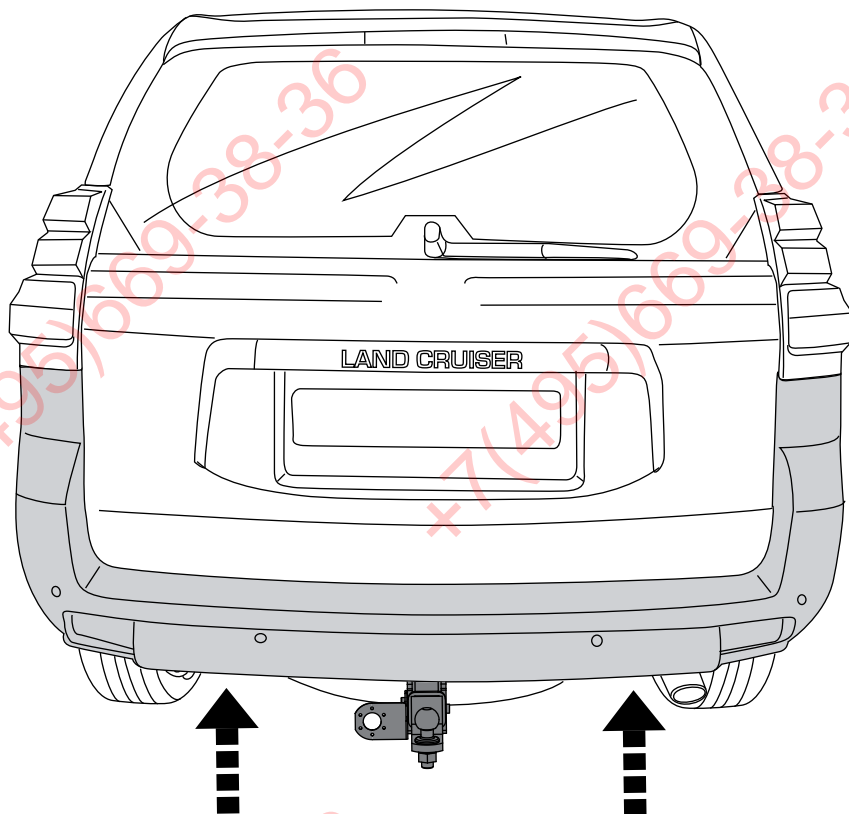
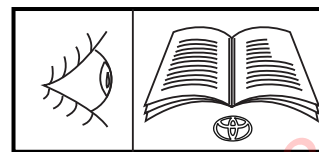

**19**

Установить бампер в последовательности  
обратной снятию (стр. 2 - 11)

**+7 (495) 669-38-36**